

# DECORATOR SERVICES

Sales@Decoratorservices.com  
decoratorservices.com

Suppliers of:

Kirsch Finial Co. Paris Texas Sahara  
Somfy BTX DS Tracks



## Ripplefold Fabrication Guide

\*\*\*Created by Decorator Services\*\*\*



# OVERVIEW

## Why Ripplefold?

A beautiful, tailored look, a Ripplefold system gently glides along the track as each fold falls evenly and perfectly into position. Master carriers that work together to eliminate flat drapery areas, giving your drapery panels a full, luxurious look.

## Benefits & Features

---

### Advantages

- Folds have a stylish, contemporary look
- Low maintenance
- Less stack back compared to pinch pleat
- Easy fabrication

### How it Works

This desired style of track system is mounted on the wall, ceiling or can be recessed. Tape is stitched to flat, hemmed panels of fabric using this guide for specifications. Once the tape is stitched, the panels snap to the carriers creating a graceful, uniform flow of ripple like folds that stack back to the very ends of the track taking up less space than conventional pleated draperies. More glass is exposed so you can enjoy more natural light and greater views.

### Ease of Fabrication

Unlike pleat stitching, Ripplefold only needs straight hemming so extra support from crinoline is unnecessary. The permanently stiffened nylon snap tape supports headings even through repeated laundering or cleaning.

Because every fabric does not look flattering with Ripplefold, the drapery fabric should be checked for compatibility with the heading system. If in doubt, a sample should be made up and installed to check appearance. Fabric requirements are easy to configure using the charts in this guide.

### Low Maintenance

The speed and ease of snapping panels into place reduces maintenance time and expense. Draperies stay tidier longer because they are handled less. Off the track, Ripplefold draperies are perfectly flat making laundering, cleaning and pressing easier and less expensive. Draperies fall into soft, natural folds when panels are snapped into carriers.

# OVERVIEW & FABRICATION

## How to Fabricate Ripplefold

### 1. Decide the following conditions

- Width of area treatment will cover (Width of track)
- Desired fullness (60%, 80%, 100% or 120%)
- One-way or two-way draw
- Butt master or overlap master

### 2. Determine the coverage per panel

For a one-way draw system you will have one panel, therefore the Coverage per panel will be equal to the width of your track.

For a two-way draw system you will have two panels, therefore the coverage per panel will be half the width of your track

### 3. Select desired fullness using the chart

Follow the chart to find your desired fullness, move down the column to the row with your panel coverage measurement. This row gives you the fabric width (hemmed), number of snaps required on tape, number of full spaces as well as the number of carriers required on the track. Due to slight manufacturing variations of ripplefold tape, It's a good idea to start sewing on the tape at the master side. That way if the tape were to come out slightly too long or short, adjustments could be made at the return end.

### 4. Measure and cut the snap tape

#### Butt Master

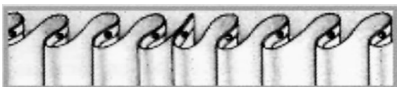

Cut off tape 2 1/4" before the first factory snap. Make a mark 1" from the first factory snap, this is where you will need to add a snap.

#### Butt Master

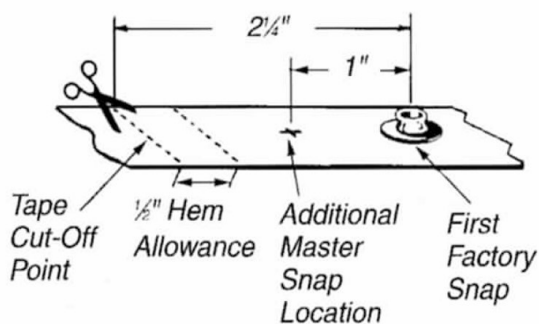

#### Overlap Master



Cut off tape 3 1/4" before the first factory snap. Make a mark 2 1/2" from the first factory snap, this is where you will need to add a snap.

#### Overlap Master

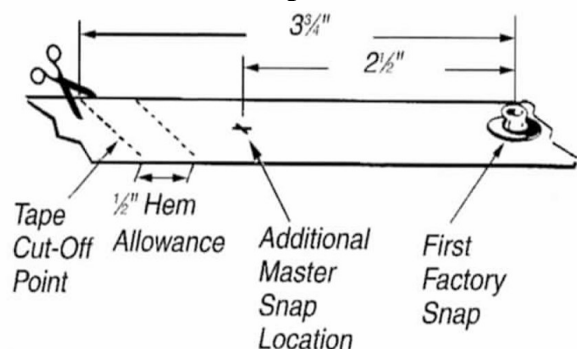

## 5. Determine your return length

Figure your return length from the last factory snap. Before cutting, add an additional 1/2" for the hem.

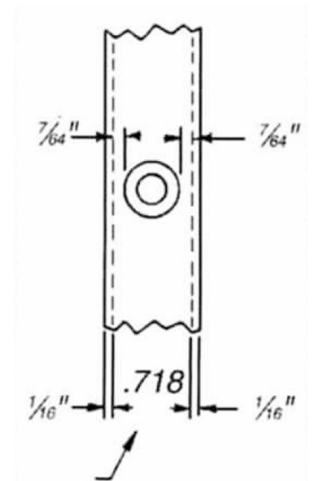
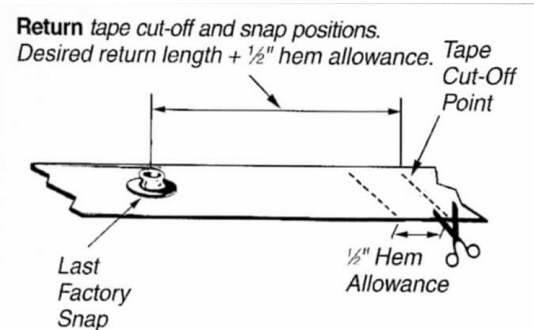

Correct Needle Spacing

## 6. Adding the additional master snap



Pierce tape at the position you have marked. Insert the male snap through the hole, then press the female snap onto the other side and rivet together using the hand tool 92901061 and a hammer. If no tool available, you can cut off a snap from your excess tape leaving extra tape on each side of the snap so you can sew it onto the tape.

## 7. Preparing your panels

Cut and hem panels to required width and desired length. Be sure to allow for track clearance plus desired off the floor clearance.

A 1" hem is sufficient for heading. The Nylon snap tape provides adequate support. For additional support for light weight fabrics, buckram can be added.

Spacing for double needle heads should be .718" or 23/32".

Place snap tape on heading of flat panel, Turn each end of tape under 1/2". Using a zipper foot, sew heading from master end. Stitch as closely as possible to top of heading to prevent the fabric from coming into contact with the track during operation.

Attach the pendants to the drapery tape snaps on the floor or work table. Pliers are sometimes needed to aid in the applying of the pendants to the drapery. Panels are now ready to be attached to the installed track. Beginning with the master carrier, simply snap panels onto the track.

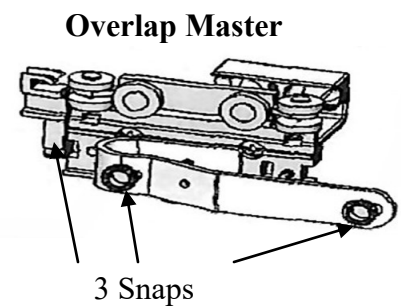
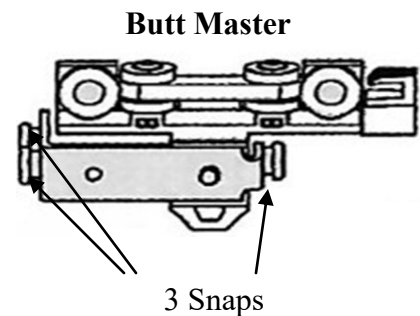

\*\*\*For Kirsch Amp Motorized traverse with butt master, there needs to be one additional carrier added per panel because there are only two snaps on this particular butt master.\*\*\*

# SAMPLE PAGE 1

**Sample 1** 14 inch track, 1-way left, 100% fullness with butt master, 3" ret.  
**Butt Master** Full spaces: 7 Carriers required: 7 # of snaps on tape: 9

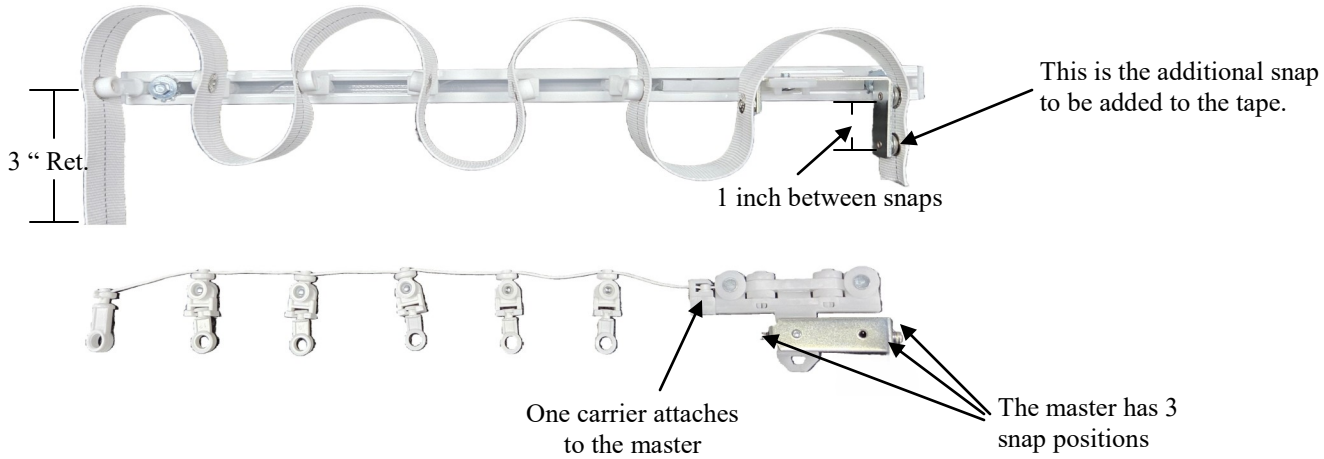

**Sample 2** 14 inch track, 1-way left, 100% fullness with overlap master, 3" ret  
**Overlap Master** Full spaces: 7 Carriers required: 7 # of snaps on tape: 9

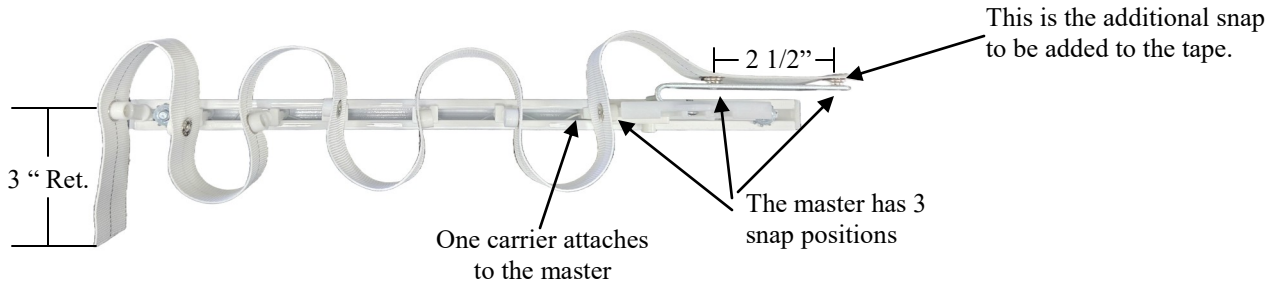

**Butt Master** 4 Inch width



**Overlap Master** 5 1/4 Inch width



**Wheeled Carrier** 5/8 inch width

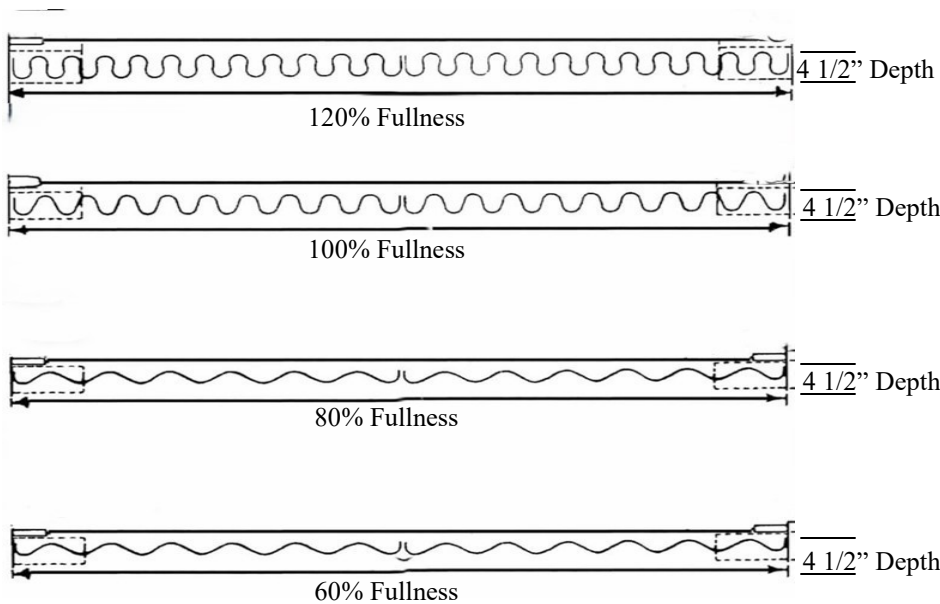

\*\*\*For Kirsch Amp motorized traverse w/ Butt master, one additional carrier is needed per panel\*\*\*

# SAMPLE PAGE 2

## One-Way Draw Example

Treatment will cover an area of 100" wide. Desired fullness is 80%. Butt style master and 3" return specified. Track system will be 100". Using the butt master chart on pg 6, locate the column for 80%, move down the column until you reach a box of at least 100". This row contains all required information for this 100" one-way treatment.

Fabric & tape width (hemmed) = 187 1/2"

Total snaps on tape (including additional snap added by workroom) = 45

Number of full spaces = 43

Number of Full Spaces	Fabric Width Hemmed (Includes 3 Inch Ret)	Panel Coverage				Approx. Stack Back 1-Way	Approx. Stack Back 2-Way per panel	Total number of snaps needed on tape	Number of Carriers required
		1 7/8" Spacing 120% Fullness	2 1/8" Spacing 100% Fullness	2 3/8" Spacing 80% Fullness	2 5/8" Spacing 60% Fullness				
39	170 1/2	70-73	79-82	88-92	98-102	27 3/4	16 1/2	41	39
41	179	74-76	83-87	93-97	103-107	29	17 1/8	43	41
43	187 1/2	77-80	88-91	98-102	108-112	30 1/4	17 3/4	45	43
45	196	81-84	92-95	103-106	113-118	31 1/2	18 3/8	47	45
47	204 1/2	85-88	96-99	107-111	119-123	32 3/4	19	49	47

## Two-Way Draw Example

Treatment will cover an area of 100" wide. Desired fullness is 80%. Butt style masters and 3" return specified. Because this will be a two-way draw system, there will be two panels with a track width of 100". Each panel will have to cover 50". Using the butt master chart on pg 6, locate the column for 80%, move down the column until you reach a box of at least 50". This row contains all required information for each panel.

Fabric & tape width (hemmed) for each panel = 102 1/2"

Total snaps on tape (including additional snap added by workroom) for each panel = 25

Number of full spaces for each panel = 23

Number of Full Spaces	Fabric Width Hemmed (Includes 3 Inch Ret)	Panel Coverage				Approx. Stack Back 1-Way	Approx. Stack Back 2-Way per panel	Total number of snaps needed on tape	Number of Carriers required
		1 7/8" Spacing 120% Fullness	2 1/8" Spacing 100% Fullness	2 3/8" Spacing 80% Fullness	2 5/8" Spacing 60% Fullness				
19	85 1/2	32-35	37-40	41-45	45-49	15 1/4	10 1/4	21	19
21	94	36-39	41-44	46-49	50-55	16 1/2	10 7/8	23	21
23	102 1/2	40-43	45-48	50-54	56-60	17 3/4	11 1/2	25	23
25	111	44-46	49-53	55-59	61-65	19	12 1/8	27	25
27	119 1/2	47-50	54-57	60-64	66-70	20 1/4	12 3/4	29	27

The examples and charts in this guide are figured for a 3 inch return. If a longer return is desired, you can simply add to your fabric and tape length for your desired return.

# Ripplefold® Fabrication Charts



**For Butt-Master Carriers**

Chart 1

Number of Full Spaces	Fabric Width Hemmed (Includes 3 Inch Return)	Panel Coverage				*Approx. Stack Back 1-Way	*Approx. Stack Back 2-Way per panel	Total number of snaps needed on tape	Number of Carriers required
		1 7/8" Spacing <b>120% Fullness</b>	2 1/8" Spacing <b>100% Fullness</b>	2 3/8" Spacing <b>80% Fullness</b>	2 5/8" Spacing <b>60% Fullness</b>				
7	34 1/2	13-13	13-14	13-16	16-18	7 3/4	6 1/2	9	7
9	43	14-16	15-19	17-21	19-23	9	7 1/8	11	9
11	51 1/2	17-20	20-23	22-26	24-28	10 1/4	7 3/4	13	11
13	60	21-24	24-27	27-30	29-34	11 1/2	8 3/8	15	13
15	68 1/2	25-28	28-31	31-35	35-39	12 3/4	9	17	15
17	77	29-31	32-36	36-40	40-44	14	9 5/8	19	17
19	85 1/2	32-35	37-40	41-45	45-49	15 1/4	10 1/4	21	19
21	94	36-39	41-44	46-49	50-55	16 1/2	10 7/8	23	21
23	102 1/2	40-43	45-48	50-54	56-60	17 3/4	11 1/2	25	23
25	111	44-46	49-53	55-59	61-65	19	12 1/8	27	25
27	119 1/2	47-50	54-57	60-64	66-70	20 1/4	12 3/4	29	27
29	128	51-54	58-61	65-68	71-76	21 1/2	13 3/8	31	29
31	136 1/2	55-58	62-65	69-73	77-81	22 3/4	14	33	31
33	145	59-61	66-70	74-78	82-86	24	14 5/8	35	33
35	153 1/2	62-65	71-74	79-83	87-91	25 1/4	15 1/4	37	35
37	162	66-69	75-78	84-87	92-97	26 1/2	15 7/8	39	37
39	170 1/2	70-73	79-82	88-92	98-102	27 3/4	16 1/2	41	39
41	179	74-76	83-87	93-97	103-107	29	17 1/8	43	41
43	187 1/2	77-80	88-91	98-102	108-112	30 1/4	17 3/4	45	43
45	196	81-84	92-95	103-106	113-118	31 1/2	18 3/8	47	45
47	204 1/2	85-88	96-99	107-111	119-123	32 3/4	19	49	47
49	213	89-91	100-104	112-116	124-128	34	19 5/8	51	49
51	221 1/2	92-95	105-108	117-121	129-133	35 1/4	20 1/4	53	51
53	230	96-99	109-112	122-125	134-139	36 1/2	20 7/8	55	53
55	238 1/2	100-103	113-116	126-130	140-144	37 3/4	21 1/2	57	55
57	247	104-106	117-121	131-135	145-149	39	22 1/8	59	57
59	255 1/2	107-110	122-125	136-140	150-154	40 1/4	22 3/4	61	59
61	264	111-114	126-129	141-144	155-160	41 1/2	23 3/8	63	61
63	272 1/2	115-118	130-133	145-149	161-165	42 3/4	24	65	63
65	281	119-121	134-138	150-154	166-170	44	24 5/8	67	65

\*The stack backs are figured as though all carriers and the master are stacked together side by side. Once the drapery panel is attached, the stack back width will grow, especially with thicker fabric. These figures are giving you a starting point to work with.

## Ripplefold® Fabrication Charts



**For Butt-Master  
Carriers**

### Chart 2

Number of Full Spaces	Fabric Width Hemmed (Includes 3 Inch Return)	Panel Coverage				*Approx. Stack Back 1-Way	*Approx. Stack Back 2-Way per panel	Total number of snaps needed on tape	Number of Carriers required
		1 7/8" Spacing <b>120% Fullness</b>	2 1/8" Spacing <b>100% Fullness</b>	2 3/8" Spacing <b>80% Fullness</b>	2 5/8" Spacing <b>60% Fullness</b>				
67	289 1/2	122-125	139-142	155-159	171-175	45 1/4	25 1/4	69	67
69	298	126-129	143-146	160-163	176-181	46 1/2	25 7/8	71	69
71	306 1/2	130-133	147-150	164-168	182-186	47 3/4	26 1/2	73	71
73	315	134-136	151-155	169-173	187-191	49	27 1/8	75	73
75	323 1/2	137-140	156-159	174-178	192-196	50 1/4	27 3/4	77	75
77	332	141-144	160-163	179-182	197-202	51 1/2	28 3/8	79	77
79	340 1/2	145-148	164-167	183-187	203-207	52 3/4	29	81	79
81	349	149-151	168-172	188-192	208-212	54	29 5/8	83	81
83	357 1/2	152-155	173-176	193-197	213-217	55 1/4	30 1/4	85	83
85	366	156-159	177-180	198-201	218-223	56 1/2	30 7/8	87	85
87	374 1/2	160-163	181-184	202-206	224-228	57 3/4	31 1/2	89	87
89	383	164-166	185-189	207-211	229-233	59	32 1/8	91	89
91	391 1/2	167-170	190-193	212-216	234-238	60 1/4	32 3/4	93	91
93	400	171-174	194-197	217-220	239-244	61 1/2	33 3/8	95	93
95	408 1/2	175-178	198-201	221-225	245-249	62 3/4	34	97	95
97	417	179-181	202-206	226-230	250-254	64	34 5/8	99	97
99	425 1/2	182-185	207-210	234-238	255-259	65 1/4	35 1/4	101	99
101	434	186-189	211-214	239-242	260-265	66 1/2	35 7/8	103	101
103	442 1/2	190-193	215-218	243-247	266-270	67 3/4	36 1/2	105	103
105	451	194-196	219-223	248-252	271-275	69	37 1/8	107	105
107	459 1/2	197-200	224-227	253-257	276-280	70 1/4	37 3/4	109	107
109	468	201-204	228-231	258-261	281-286	71 1/2	38 3/8	111	109
111	476 1/2	205-208	232-235	262-266	287-291	72 3/4	39	113	111
113	485	209-211	236-240	267-271	292-296	74	39 5/8	115	113
115	493 1/2	212-215	241-244	272-276	297-301	75 1/4	40 1/4	117	115
117	502	216-219	245-248	277-280	302-307	76 1/2	40 7/8	119	117
119	510 1/2	220-223	249-252	281-285	308-312	77 3/4	41 1/2	121	119
121	519	224-226	253-257	286-290	313-317	79	42 1/8	123	121
123	527 1/2	227-230	258-261	291-295	318-322	80 1/4	42 3/4	125	123
125	536	231-234	262-265	296-299	323-328	81 1/2	43 3/8	127	125

\*The stack backs are figured as though all carriers and the master are stacked together side by side. Once the drapery panel is attached, the stack back width will grow, especially with thicker fabric. These figures are giving you a starting point to work with.

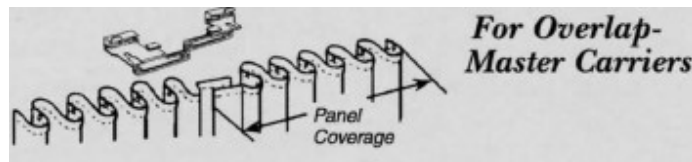

Chart 3

Number of Full Spaces	Fabric Width Hemmed (Includes 3 Inch Return)	Panel Coverage				*Approx. Stack Back 1-Way	*Approx. Stack Back 2-Way per panel	Total number of snaps needed on tape	Number of Carriers required
		1 7/8" Spacing <b>120% Fullness</b>	2 1/8" Spacing <b>100% Fullness</b>	2 3/8" Spacing <b>80% Fullness</b>	2 5/8" Spacing <b>60% Fullness</b>				
7	36	11-14	12-16	14-17	14-19	9	7 3/4	9	7
9	44 1/2	15-18	17-20	18-22	20-24	10 1/4	8 3/8	11	9
11	53	19-21	21-24	23-27	25-30	11 1/2	9	13	11
13	61 1/2	22-25	25-28	28-32	31-35	12 3/4	9 5/8	15	13
15	70	26-29	29-33	33-36	36-40	14	10 1/4	17	15
17	78 1/2	30-33	34-37	37-41	41-45	15 1/4	10 7/8	19	17
19	87	34-36	38-41	42-46	46-51	16 1/2	11 1/2	21	19
21	95 1/2	37-40	42-45	47-51	52-56	17 3/4	12 1/8	23	21
23	104	41-44	46-50	52-55	57-61	19	12 3/4	25	23
25	112 1/2	45-48	51-54	56-60	62-66	20 1/4	13 3/8	27	25
27	121	49-51	55-58	61-65	67-72	21 1/2	14	29	27
29	129 1/2	52-55	59-62	66-70	73-77	22 3/4	14 5/8	31	29
31	138	56-59	63-67	71-74	78-82	24	15 1/4	33	31
33	146 1/2	60-63	68-71	75-79	83-87	25 1/4	15 7/8	35	33
35	155	64-66	72-75	80-84	88-93	26 1/2	16 1/2	37	35
37	163 1/2	67-70	76-79	85-89	94-98	27 3/4	17 1/8	39	37
39	172	71-74	80-84	90-93	99-103	29	17 3/4	41	39
41	180 1/2	75-78	85-88	94-98	104-108	30 1/4	18 3/8	43	41
43	189	79-81	89-92	99-103	109-114	31 1/2	19	45	43
45	197 1/2	82-85	93-96	104-108	115-119	32 3/4	19 5/8	47	45
47	206	86-89	97-101	109-112	120-124	34	20 1/4	49	47
49	214 1/2	90-93	102-105	113-117	125-129	35 1/4	20 7/8	51	49
51	223	94-96	106-109	118-122	130-135	36 1/2	21 1/2	53	51
53	231 1/2	97-100	110-113	123-127	136-140	37 3/4	22 1/8	55	53
55	240	101-104	114-118	128-131	141-145	39	22 3/4	57	55
57	248 1/2	105-108	119-122	132-136	146-150	40 1/4	23 3/8	59	57
59	257	109-111	123-126	137-141	151-156	41 1/2	24	61	59
61	265 1/2	112-115	127-130	142-146	157-161	42 3/4	24 5/8	63	61
63	274	116-119	131-135	147-150	162-166	44	25 1/4	65	63
65	282 1/2	120-123	136-139	151-155	167-171	45 1/4	25 7/8	67	65

\*The stack backs are figured as though all carriers and the master are stacked together side by side. Once the drapery panel is attached, the stack back width will grow, especially with thicker fabric. These figures are giving you a starting point to work with.

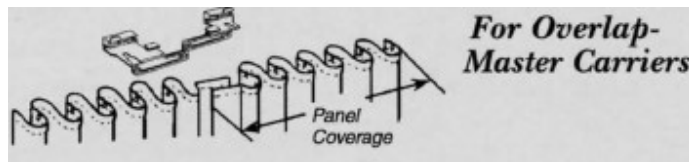

Chart 4

Number of Full Spaces	Fabric Width Hemmed (Includes 3 Inch Return)	Panel Coverage				*Approx. Stack Back 1-Way	*Approx. Stack Back 2-Way per panel	Total number of snaps needed on tape	Number of Carriers required
		1 7/8" Spacing <b>120% Fullness</b>	2 1/8" Spacing <b>100% Fullness</b>	2 3/8" Spacing <b>80% Fullness</b>	2 5/8" Spacing <b>60% Fullness</b>				
67	291	124-126	140-143	156-160	172-177	46 1/2	26 1/2	69	67
69	299 1/2	127-130	144-147	161-165	178-182	47 3/4	27 1/8	71	69
71	308	131-134	148-152	166-169	183-187	49	27 3/4	73	71
73	316 1/2	135-138	153-156	170-174	188-192	50 1/4	28 3/8	75	73
75	325	139-141	157-160	175-179	193-198	51 1/2	29	77	75
77	333 1/2	142-145	161-164	180-184	199-203	52 3/4	29 5/8	79	77
79	342	146-149	165-169	185-188	204-208	54	30 1/4	81	79
81	350 1/2	150-153	170-173	189-193	209-213	55 1/4	30 7/8	83	81
83	359	154-156	174-177	194-198	214-219	56 1/2	31 1/2	85	83
85	367 1/2	157-160	178-181	199-203	220-224	57 3/4	32 1/8	87	85
87	376	161-164	182-186	204-207	225-229	59	32 3/4	89	87
89	384 1/2	165-168	187-190	208-212	230-234	60 1/4	33 3/8	91	89
91	393	169-171	191-194	213-217	235-240	61 1/2	34	93	91
93	401 1/2	172-175	195-198	218-222	241-245	62 3/4	34 5/8	95	93
95	410	176-179	199-203	223-226	246-250	64	35 1/4	97	95
97	418 1/2	180-183	204-207	227-231	251-255	65 1/4	35 7/8	99	97
99	427	184-186	208-211	232-236	256-261	66 1/2	36 1/2	101	99
101	435 1/2	187-190	212-215	237-241	262-266	67 3/4	37 1/8	103	101
103	444	191-194	216-220	242-245	267-271	69	37 3/4	105	103
105	452 1/2	195-198	221-224	246-250	272-276	70 1/4	38 3/8	107	105
107	461	199-201	225-228	251-255	277-282	71 1/2	39	109	107
109	469 1/2	202-205	229-232	256-260	283-287	72 3/4	39 5/8	111	109
111	478	206-209	233-237	261-264	288-292	74	40 1/4	113	111
113	486 1/2	210-213	238-241	265-269	293-297	75 1/4	40 7/8	115	113
115	495	214-216	242-244	270-274	298-303	76 1/2	41 1/2	117	115
117	503 1/2	217-220	245-248	275-279	304-308	77 3/4	42 1/8	119	117
119	512	221-224	249-253	280-283	309-313	79	42 3/4	121	119
121	520 1/2	225-228	254-257	284-288	314-318	80 1/4	43 3/8	123	121
123	529	229-231	258-261	289-293	319-324	81 1/2	44	125	123
125	537 1/2	232-235	262-265	294-298	325-329	82 3/4	44 5/8	127	125

\*The stack backs are figured as though all carriers and the master are stacked together side by side. Once the drapery panel is attached, the stack back width will grow, especially with thicker fabric. These figures are giving you a starting point to work with.